

Electro-Pneumatic Positioner



PET/PXT Series

Instruction Manual



Table of Contents

1	Introduction -----	4
1.1	General information for the user-----	4
1.2	Requirement for safety-----	5
1.3	Basic safety instructions for use in Ex area-----	6
1.4	Conditions to maintain intrinsic safety (Ex i)-----	6
2	Description of Products -----	7
2.1	Function-----	7
2.2	Features-----	7
2.3	Options-----	7
2.4	Applications-----	7
2.5	Label-----	8
2.6	Product Code-----	9
2.7	Specification-----	10
2.7.1	Positioner-----	10
2.7.2	Position transmitter(Optional)-----	10
2.7.3	Limit Switch(Optional)-----	11
2.8	Operation logic-----	12
2.9	Parts and Assembly-----	13
2.9.1	Standard type-----	13
2.9.2	With Position transmitter type-----	14
2.10	Dimension drawings-----	15
2.10.1	PET/PXT-L Dimensions-----	15
2.10.2	PET/PXT-R Dimensions-----	17
3	Installation -----	19
3.1	Safety-----	19
3.2	PET/PXT-L installation -----	19
3.3	PET/PXT-R installation -----	21
3.3.1	Fork lever type-----	21

3.3.2	NAMUR Type	21
4	Air connection	22
4.1	Notice	22
4.2	PET/PXT-L air connection	22
4.3	PET/PXT-L RA/DA action setting	22
4.4	PET/PXT-R air connection	23
4.5	PET/PXT-R RA/DA action setting	23
5	Power connection	24
5.1	Flame proof type power connection	24
5.2	Intrinsically safe type power connection	26
5.3	With Position transmitter	27
5.4	With Limit switch	28
5.5	With Position transmitter and Limit switch	28
6	Adjustment	29
6.1	Zero and Span Adjustment	29
6.2	Position transmitter Setting(Optional)	30
7	Troubleshooting	31
7.1	Common problems	31
7.2	Install orifice	31
7.3	Adjust Potentiometer gear	32
7.4	Other problems and resolution	33

1 Introduction

1.1 General information for the user

This instruction includes installation, operation, maintenance, and parts information for Max-Air Technology PET/PXT Valve Positioners. Keep these instructions in a location which is easily accessible to every user and make these instructions available to every new owner of the device.



- Installation, commissioning and maintenance of the product may only be performed by trained specialist personnel who have been authorized by the plant operator to do so.
- To avoid possible injury to personnel or damage to valve parts, WARNING, CAUTION and NOTICE should be strictly followed.
- Before installing or commissioning, be sure to read and thoroughly understand the product manual and operate the product properly.
- Operators must strictly observe the applicable national regulations with regards to installation, function tests, repairs, and maintenance of electrical products.
- For additional information or if specific problems occur that are not discussed in these instructions, contact the manufacturer.

The manual can be altered or revised without any prior notice.
Please visit our website (www.maxairtech.com) check the latest documentation.

Manual version	12/2020
----------------	---------

1.2 Requirement for safety

This manual contains notices you have to observe in order to ensure your personal safety, as well as to prevent damage to property. These safety instructions are intended to prevent hazardous situations and/or equipment damage. For the safety, it is important to follow the instructions in the manual.

-
-  **WARNING** Failure to observe the warning may result in serious injuries or death.
-  **CAUTION** Failure to observe this warning may result in product failure or injuries.
-  **NOTICE** Failure to observe this warning may result in product failure or performance degradation.
-

Safety notes

 **CAUTION**

- Only trained and authorized person should operate machinery and equipment.
 - Do not use this positioner out of the range of its specifications as this can cause failure.
 - Do not service or attempt to remove product and machinery/equipment until safety is confirmed.
 - Before loosening the pneumatic lines and valves, turn off the pressure and vent the pneumatic lines.
 - Before reaching into the device or the equipment, switch off the power supply and secure to prevent reactivation.
 - Observe applicable accident prevention and safety regulations for electrical equipment.
-

1.3 Basic safety instructions for use in Ex area

To prevent the risk of explosion, observe not only the basic safety instructions in the respective operating instructions for operation in the Ex area, but also the following.

 **WARNING**

- Observe the applicable safety regulations (also national safety regulations) as well as the general rules of technology for construction and operation.
 - Make sure that the device is suitable for the area of use.
 - Check the positioner's certified and permitted explosion proof range.
 - Close all unnecessary cable glands with lock screws approved for the explosions area.
 - PXT series has 2 conduit entries. Flameproof cable must be used for cable entry, and for unused cable entry, flameproof blind cable plug should be used.
 - PXT series is certified under flame proof (Ex db mb IIB/IIC T6/T5 Gb).
Explosion proof zones 1 and 2.
-

1.4 Conditions to maintain intrinsic safety (Ex i)

 **WARNING**

- Connect the device with type of protection "Intrinsic safety" solely to an intrinsically safe circuit.
 - Observe the specifications for the electrical data on the certificate and in technical data.
 - PXT series is certified under intrinsically safe (Ex ia IIC T6/T5 Gb).
Explosion proof zones 0, 1 and 2.
-

Intrinsic safety explosion standard

Explosion regulations	IEC 60079-0:2017, IEC 60079-1:2014-06 IEC 60079-18:2017, IEC 60079-11:2011		
Explosion proof	Ex ia IIC T5/T6 Gb		
Barrier specifications	Ui	li	Pi
Main power	28V	101mA	707mW

2 Description of products

2.1 Function

Electro-Pneumatic valve positioner PET/PXT series controls the valve stroke in response to an input signal of 4~20mA DC from the control panel, DCS or calibrator.

2.2 Features

- Applied to various control valve system
- Fast response time, excellent stability and durability
- Simple zero and span adjustment
- IP 66 enclosure
- Easy maintenance due to built-in module type
- By-pass valve (A/M switch) installed
- Air connection part is designed for detachability and it can be changed PT/NPT tapping threads in the field easily

2.3 Options

- Position transmitter(4~20mA DC Feedback signal)
- Limit switch (Mechanical or Proximity type)

2.4 Applications

The PET/PXT is mounted on pneumatic control valves and is used for fluid control in industrial parts.

- Oil and gas
- Chemicals
- Power plant
- Paper
- Water treatment
- Pharmaceutical
- Printing and dyeing processing
- Food and beverage
- Etc.

Electro-Pneumatic Positioner
 PET/P Series
 XT

2.5 Label

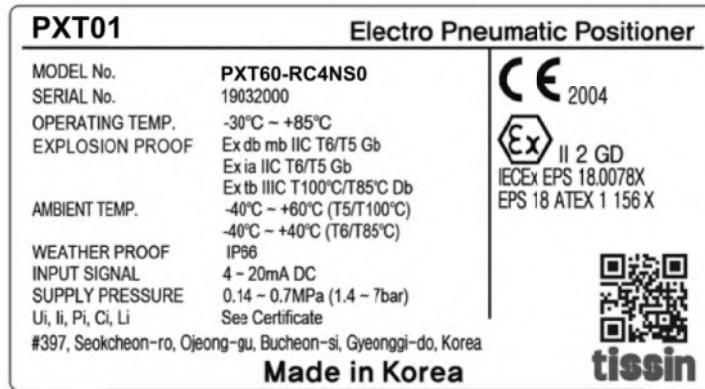

Item	Description
MODEL No.	Indicates model number.
SERIAL No.	Indicates serial number.
OPERATING TEMP	Indicates allowable operating temperature.
EXPLOSION PROOF	Indicates certified explosion proof grade.
AMBIENT TEMP.	Indicates explosion proof temperature. This temperature range must be observed when using in explosion-proof areas.
WEATHER PROOF	Indicates enclosure grade.
INPUT SIGNAL	Indicates input signal range.
SUPPLY PRESSURE	Indicates supply pressure range.

2.6 Product Code

Model	PET/PXT-						
Acting Type	Linear Type	L					
	Rotary Type	R					
Explosion proof type	Non-Explosion type	N					
	Ex dmb IIB T5/T6	B					
	Ex dmb IIC T5/T6	C					
	Ex ia IIC T5/T6	A					
	ATEX & IECEX	X					
	Ex db mb IIB/IIC T6/T5 Gb						
	Ex ia IIC T6/T5 Gb						
	Ex tb IIIC T85°C/T100°C Db IP66						
Connection type	<u>Conduit Entry</u>	<u>Air Connection</u>					
	G(PF)1/2	PT1/4	1				
	G(PF)1/2	NPT1/4	2				
	NPT1/2	NPT1/4	3				
	M20	NPT1/4	4				
	M20	G1/4	5				
Linear lever type	10~40mm		1				
	40~70mm		2				
	70~100mm		3				
	100~150mm		4				
Rotary lever type	M6 x 34L (Fork lever type)		1				
	NAMUR Type		5				
Operating Temp.	-20~70°C (Standard)					S	
	-20~120°C*					H	
	-40~70°C					L	
Options*	None						0
	With Position transmitter (4~20mA)*						1
	With Limit Switch *						2
	With Limit Switch (Explosion proof type)						3
	With Position transmitter and Limit Switch*						4
	With Position transmitter and Limit Switch (Explosion proof type)						5
	With external Limit switch mounting device						6
	With Position transmitter and external Limit switch mounting device*						7

Note*

1. High temperature (-20°C~120°C) positioner must be Non-explosion proof type.
2. Options number 1, 2, 4, 7 must be Non-explosion proof type.

2.7 Specification

2.7.1 Positioner

Model		PET/PXT-L		PET/PXT-R	
		Single	Double	Single	Double
Input signal		4~20mA DC			
Impedance		250±15Ω			
Supply pressure		0.14~0.7MPa			
Stroke		10~150mm		0~90 ⁰	
Air connection		PT(NPT) 1/4			
Gauge connection		PT(NPT) 1/8			
Conduit		G(PF) 1/2 or NPT 1/2			
Explosion proof type		Ex db mb IIB/IIC T6/T5 Gb Ex ia IIC T6/T5 Gb Ex tb IIIC T85℃/T100℃ Db			
Degree of protection		IP66			
Ambient Temp.	Operating Temp.	-20℃ ~ 70℃ (Standard), -40℃ ~ 70℃ (Low Temp.), -20℃ ~ 120℃ (High Temp.)			
	Explosion proof Temp.	-40℃~60℃(T5/T100℃) / -40℃~40℃(T6/T85℃)			
Linearity		±1.0% F.S	±2.0% F.S	±1.0% F.S	±2.0% F.S
Sensitivity		±0.2% F.S	±0.5% F.S	±0.2% F.S	±0.5% F.S
Hysteresis		±1.0% F.S			
Repeatability		±0.5% F.S			
Air consumption		Below 2.5LPM (Sup=0.14MPa)			
Flow capacity		Over 80LPM (Sup=0.14MPa)			
Material		Aluminum die casting			
Weight		2.8kg			

2.7.2 Position transmitter (Option)

Item type	Specification
Input voltage	9~30V DC
Output current	4~20mA DC
Connection type	2 Wire Type
Impedance	Max.600Ω / 30V
Range of temperature	-40℃ ~ 85℃
Linearity	±1%
Sensitivity	±0.2%
Hysteresis	1%

2.7.3 Limit Switch (Option)

Item type	Specification
Switch type	2 x SPDT
Degree of protection	IEC IP40
Rating (AC)	16A 1/2HP 125/250VAC
Rating (DC)	0.6A @ 125VDC, 0.3A @ 250VDC
Durability	Min. 100,000 @ 30 operation / min
Temperature rating	-25°C~80°C
Electric shock	Class I
Position Indicator	Open : Yellow , Close : Red

2.8 Operation Logic

The diaphragm valve moves downward. The movement of diaphragm valves acts on Feedback spring through Feedback lever and Flapper increases torque to the left pull. The diaphragm valve is balanced at the position between the above spring torque and magnetic field strength generated by the input current. Gain suppression spring is used to immediately feedback the movement of the Pilot Valve to the Flapper and it increases the loop* stability.

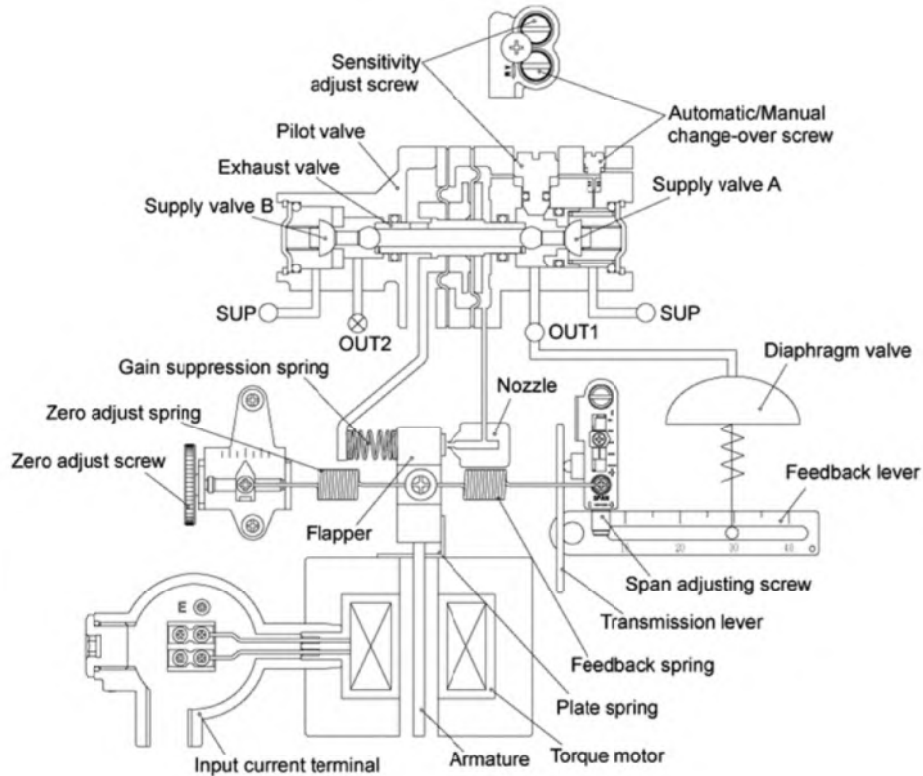

<PET/PXT-L Operation logic>

- * The diagrams above explanations based on PET/PXT-L linear type and Diaphragm valve of RA (Reverse Action) type. PET/PXTR rotary type is same as Operation logic of PET/PXT-L linear type except feedback structure.
- * Nozzle back pressure internal pressure of Nozzle depends on the control the Nozzle by the Flapper.
- * Loop Positioner and Control valve consist of closed-circuit through Feedback lever.

2.9 Parts and Assembly

2.9.1 Standard type

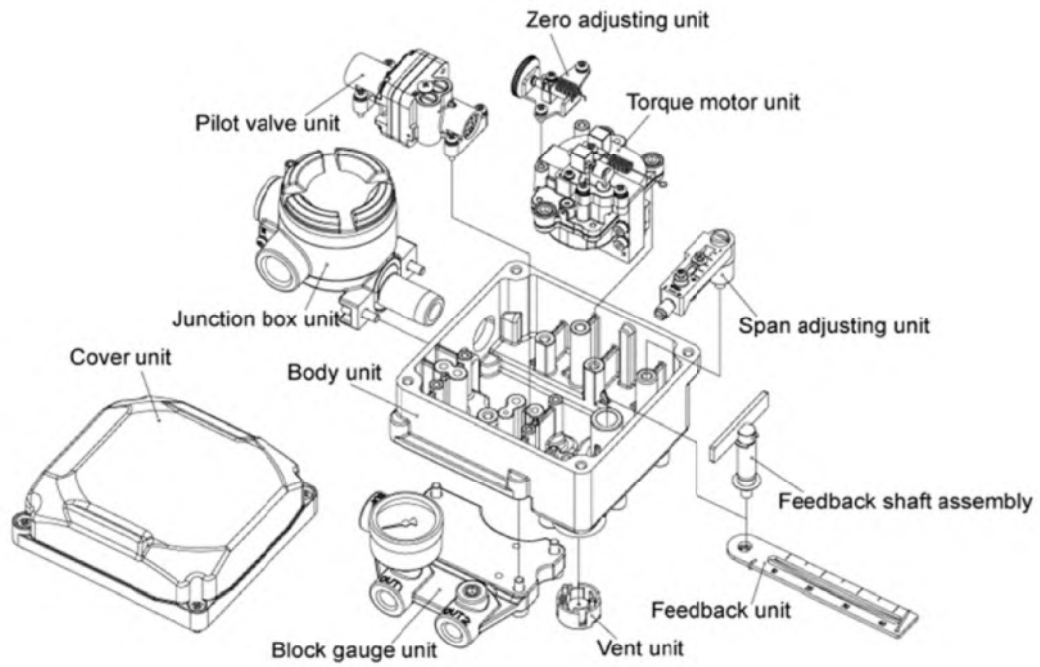

2.9.2 With Position transmitter type

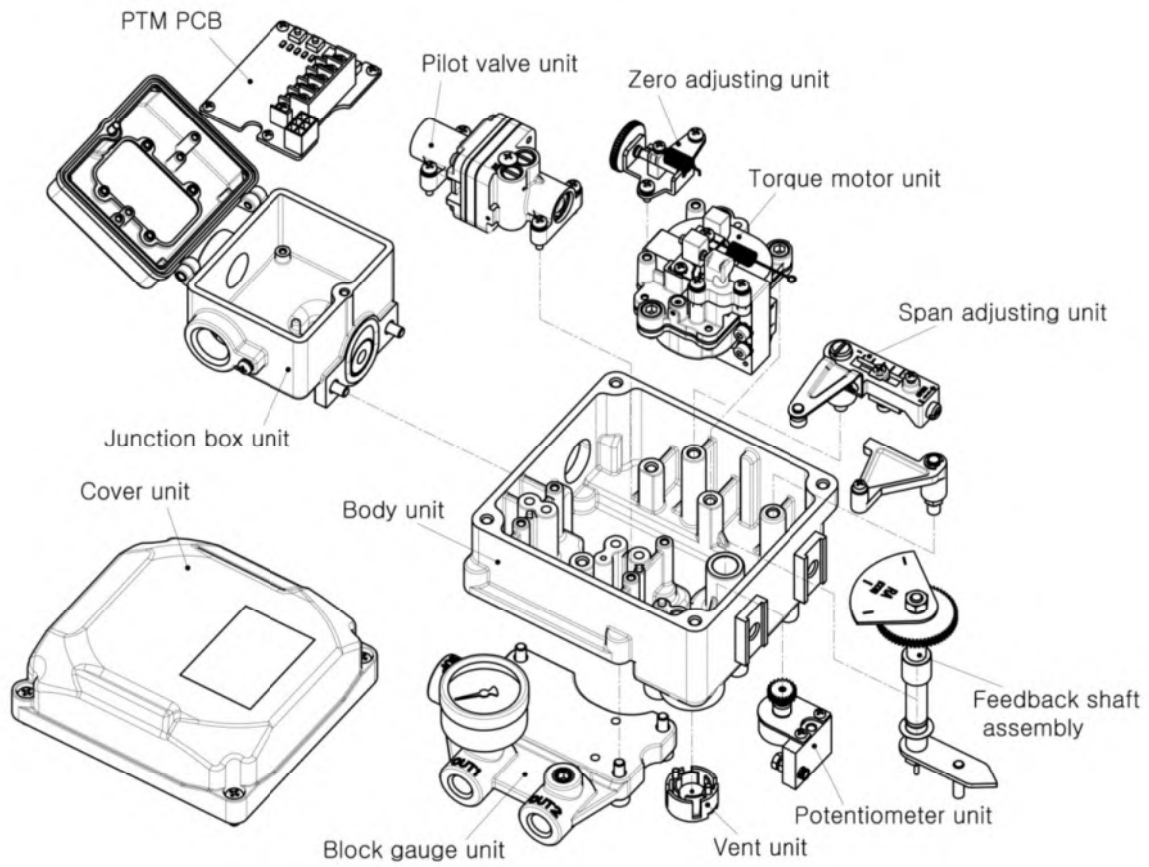

2.10 Dimension Drawings

2.10.1 PET/PXT-L Dimensions

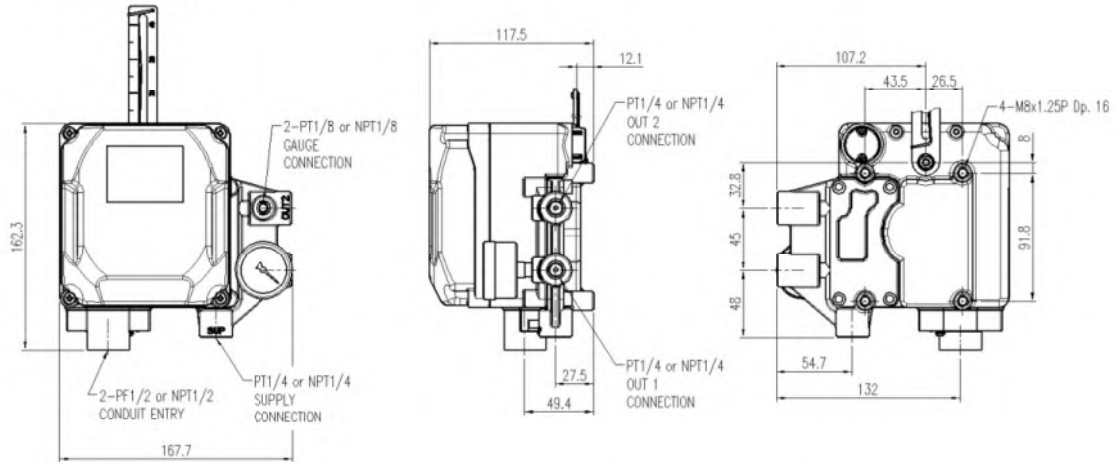

<PET/PXT-L Intrinsically safe type / Non-Explosion proof type Dimension>

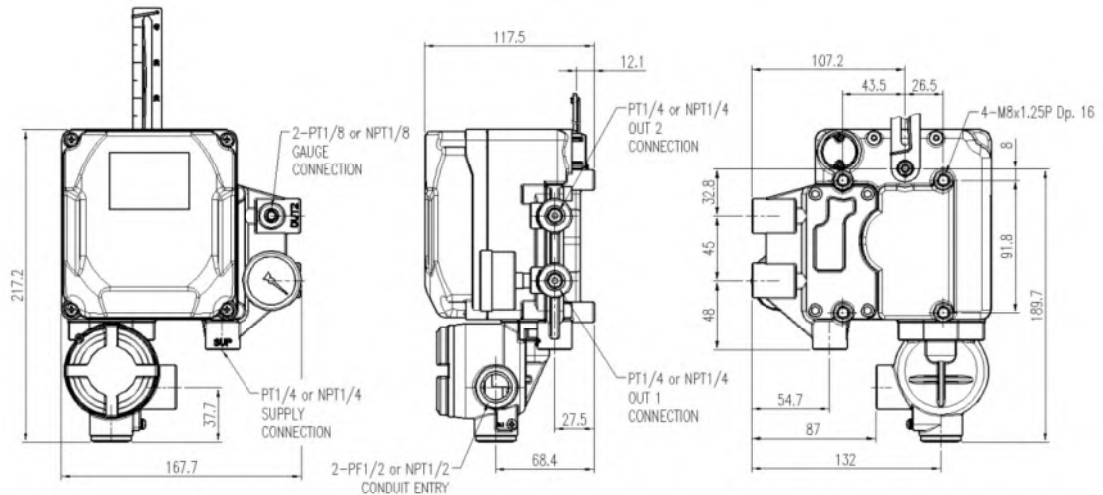

<PET/PXT-L Flame proof type / ATEX & IECEx type Dimension >

**Electro-Pneumatic Positioner
PET/PXT Series**

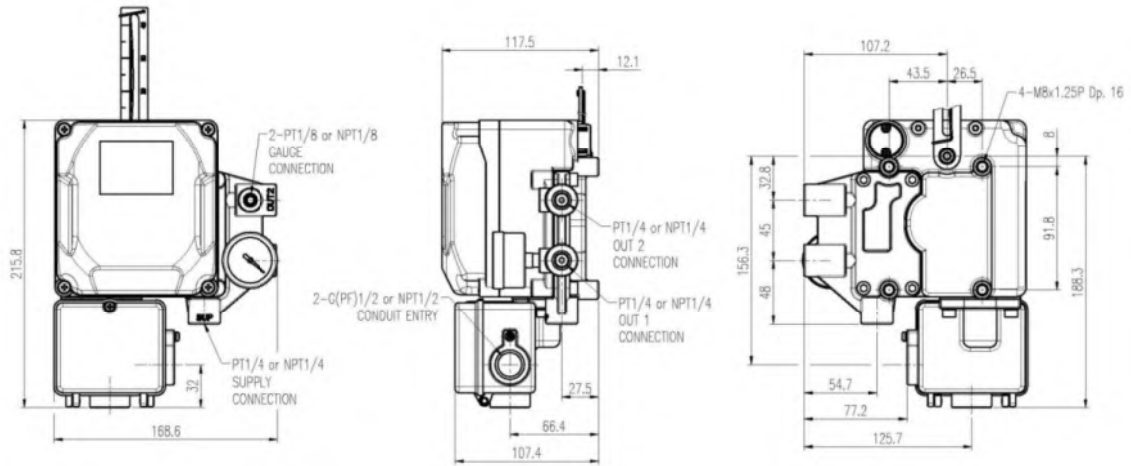

<PET/PXT-L with Position transmitter type Dimension>

**Electro-Pneumatic Positioner
PET/PXT Series**

2.10.2 PET/PXT-R Dimensions

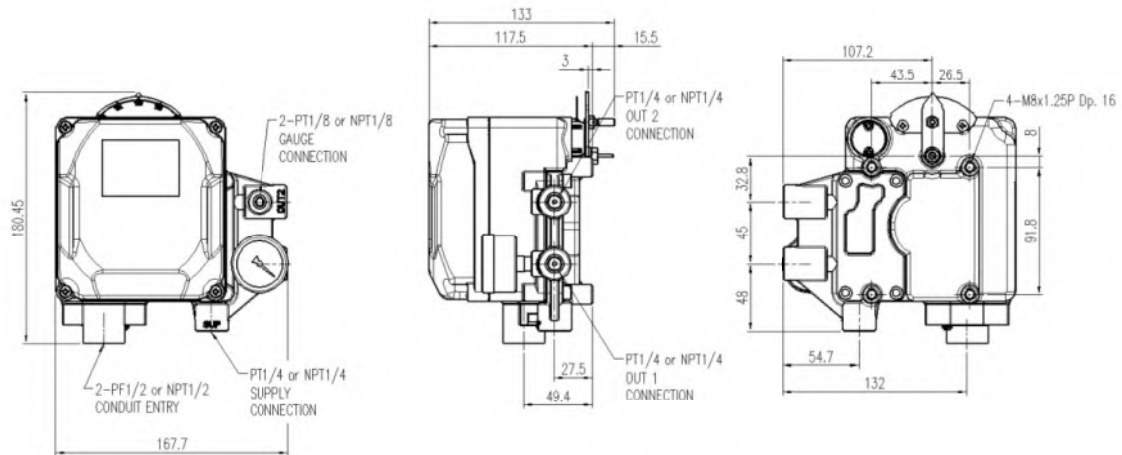

<PET/PXT-R Intrinsically safe type / Non-Explosion proof type Dimension>

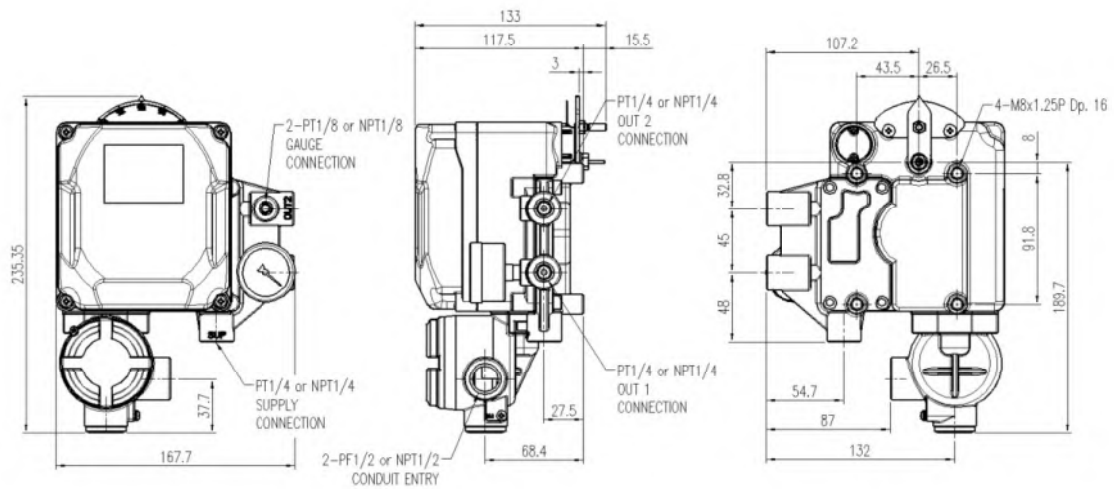

<PET/PXT-R Flame proof type / ATEX & IECEx type Dimension>

**Electro-Pneumatic Positioner
PET/PXT Series**

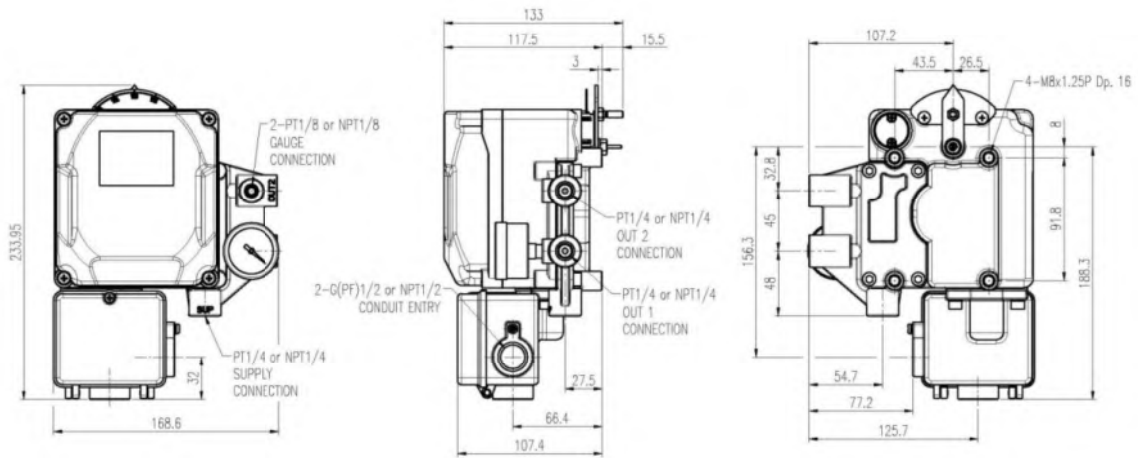

<PET/PXT-R with Position transmitter type Dimension>

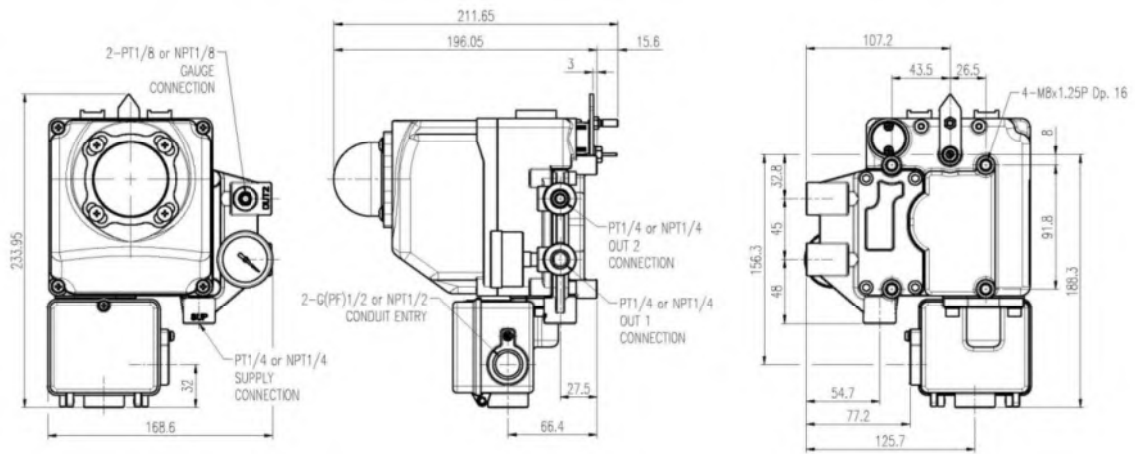

<PET/PXT-R with Limit switch type / with Position transmitter and Limit switch type Dimension>

3 Installation

3.1 Safety

⚠ WARNING

When installing a positioner, please ensure to read and follow safety instruction.

- Make a space needed for maintenance on the setting area.
 - Cut supply pressure and release compressed air in positioner and actuator in advance.
-

3.2 PET/PXT-L Installation

⚠ CAUTION

Proper bracket must be made in order to adapt the positioner on the actuator yoke. Please consider following important points when a bracket is being designed.

- Check if feedback lever is parallel to the ground at 50% of the valve stroke. <Figure 1>
 - Feedback lever connection with the pin of the actuator clamp should be installed in such a way that the valve stroke and numbers which indicated on the feedback lever must be fitted. <Figure2>
-

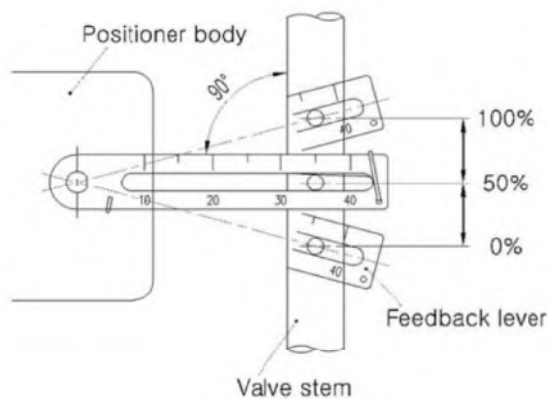

<Figure 1>

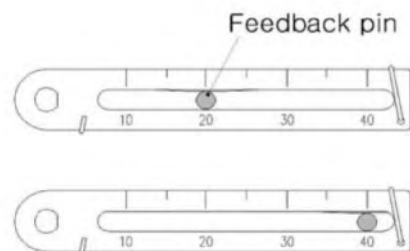

<Figure 2>

PET/PXT-L bracket Installation

Assemble the positioner with the bracket made in previous step by fastening the bolts.
Please refer to the backside of the positioner for size of the bolts. The standard bolt size is M8 x 1.25P.

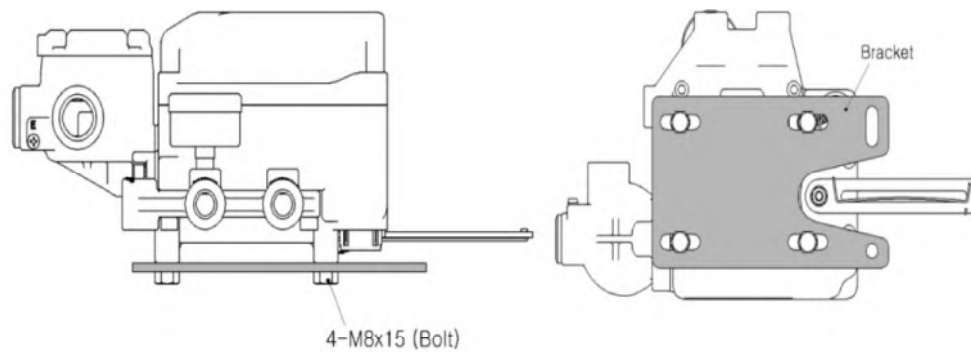

< PET/PXT-L Bracket Installation Example >

⚠ CAUTION

- After installing the positioner, operate the valve from 0% to 100% stroke by using direct air to the actuator (manual position). On both 0% and 100%, the feedback lever should not touch the lever stopper, which is located on the backside of the positioner.
 - If the feedback lever touches the stopper, the positioner should be installed further away from the yoke.
-

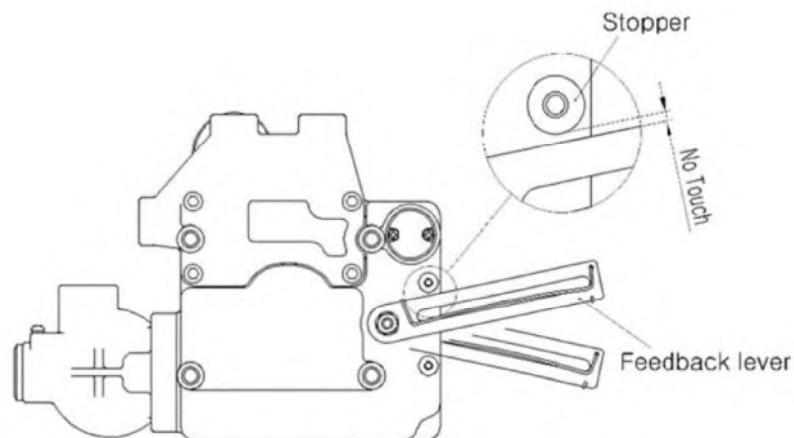

<PET/PXT-L Feedback lever should not touch lever stopper>

3.3 PET/PXT-R Installation

PET/PXT-R Standard bracket (included with positioner) contains two components. The the bracket can be used for both fork lever and NAMUR lever type.

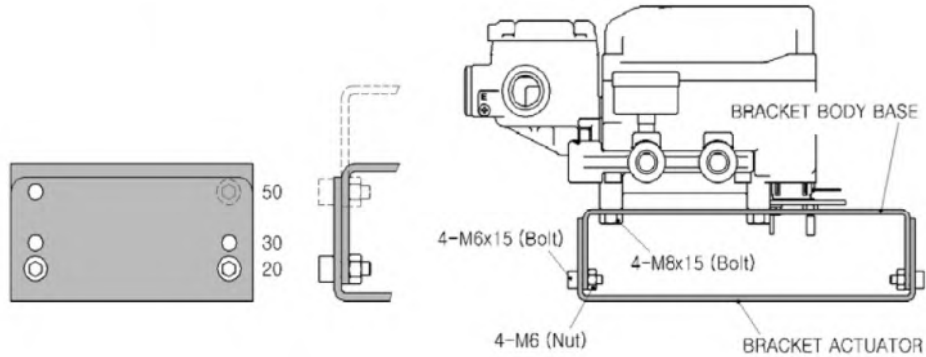

<PET/PXT-R Bracket Install Example>

3.3.1 Fork Lever Type

Install the fork lever to actuator as shown below. Install the positioner feedback shaft and actuator spindle so that the concentrically layered.

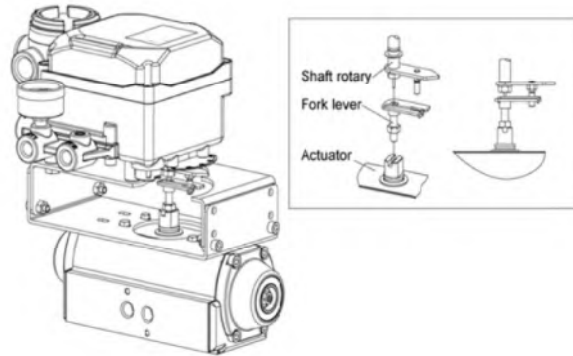

3.3.2 NAMUR Type

Insert positioner feedback shaft and actuator spindle groove and tighten bracket.

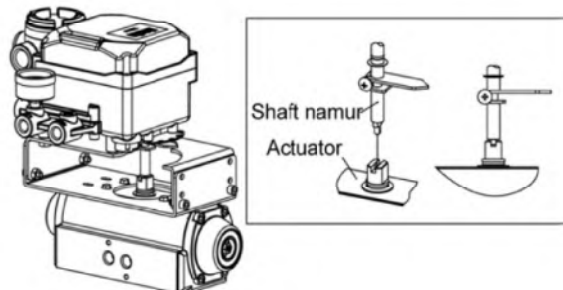

4 Air connection

4.1 Notice

! NOTICE

- PET/PXT Series is designed to increase the input current signal and **OUT1** port pneumatic output increases.
 - The products will be shipped **RA** (Reverse Action) that is when the input signal increases valves will be open.
 - If you want to use **DA** (Direct Action), must replace the pipe, span and pipeline route.
-

4.2 PET/PXT-L air connection

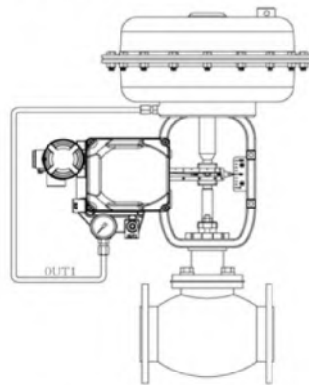

<PET/PXT-LSingle actuator>

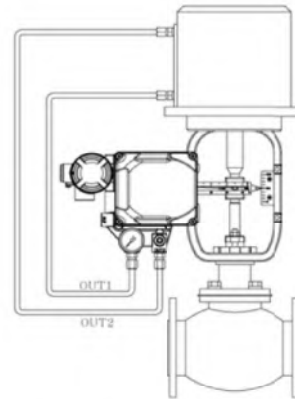

<PET/PXT-L Double actuator>

4.3 PET/PXT-L RA/DA action setting

For double acting, as shown below the piping connection and span position can be changed depends on RA/DA. The product is set to RA at factory.

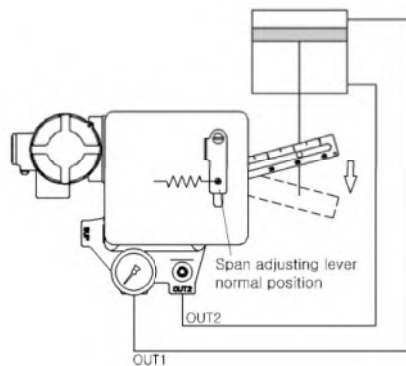

<Direct Action >

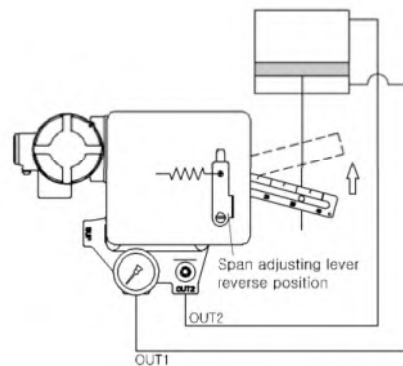

<Reverse Action>

4.4 PET/PXTR air connection

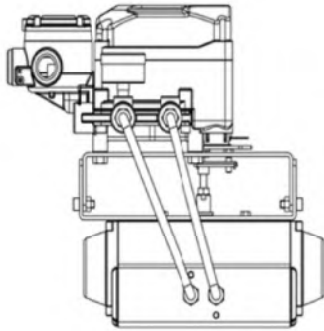

PET/PXT-R Double type actuator >

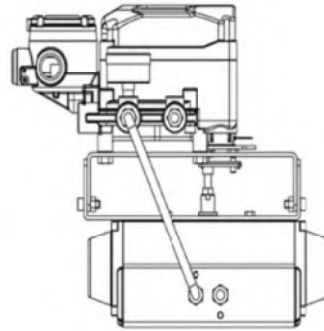

PET/PXT-RR Single actuator >

4.5 PET/PXT-R RA/DA action setting

If the valve is used for DA (Direct Action), the input signal will be increased. If cam is rotated counter-clockwise, RA will face up to the side of the cam. If cam is rotated clockwise, the DA will face up to the side of the cam.

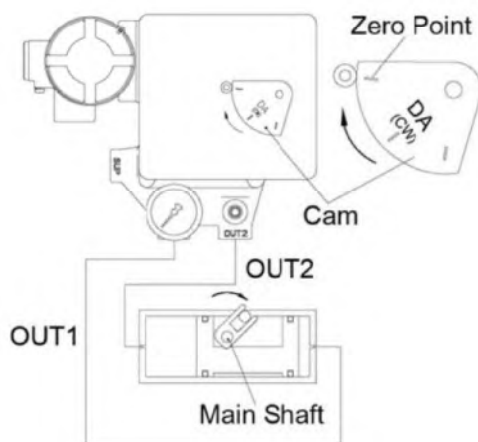

<DA Type>

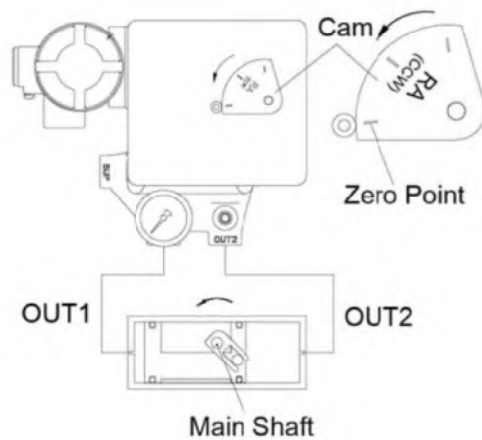

<RA Type>

5 Power Connection

⚠ WARNING

- Always check that the electrical load is within the range stated on the nameplate. Failure to remain within electrical ratings may result in damage to or premature failure of the electrical switches, sensors or transmitter electronics.
 - Check polarity of + and – exactly and connect wires.
-

5.1 Flame proof type power connection

⚠ WARNING

- Be sure that exterior lead-in wiring to the terminal box is based on the guidelines for explosion-protection of manufactory electric equipment when being used as a flame proof, explosion proof construction.
 - Do not remove terminal cover in a hazardous location while the power is on.
 - Covers for the terminal and body should be in place while operating.
-

Cable Gland Connection

- ① Be sure to use the flameproof-approved wires and cable glands in the gas area or in the potentially-explosive area. Use the cables suitable for the diameter of the NBR packing when using the flameproof-approved cable glands.
- ② Insert the terminal connection into terminal box and lock completely.
- ③ Insert washer and rubber packing, and fasten the cable gland completely.

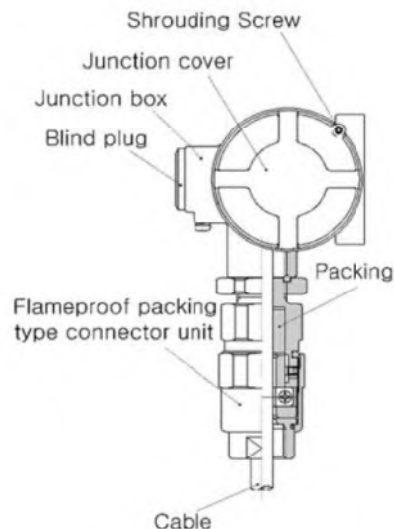

<Flame proof / ATEX & IECEx approved cable gland>

Electrical Wiring

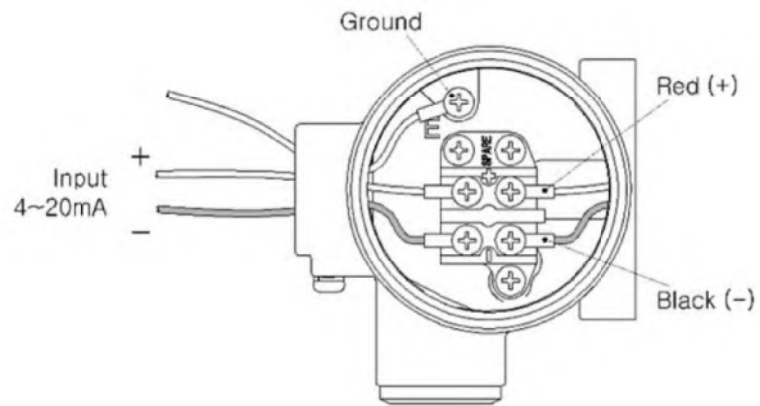

<Flame proof type / ATEX & IECEx type Terminal box>

- ① Open terminal box cover.
- ② Locate the poles and connect them properly.
Make sure to fasten the connection.
- ③ Connect Ground cable.
- ④ Close back the terminal box cover

5.2 Intrinsically safe type power connection

WARNING

PET/PXT series positioners are designed under intrinsically safe procedures and restrictions. However, intrinsically safe systems can be damaged from electronic energies from other electronic devices. To avoid any system damages, please read the following.

- Differentiate intrinsically safe type circuit with other types of circuit clearly.
 - Apply proper protection device to prevent static electricity.
 - If possible, minimize the use of inductance and capacitance. If they must be used, set the devices at lower level than the maximum level.
 - Protect the wires from damages.
 - Grounding must be done properly according to the field's procedures.
-

Electrical Wiring

- ① Open the terminal box cover by loosening the fixing bolt on the terminal box cover.
- ② Connect external + to internal + and external - to internal -.
- ③ Connect Ground Cable.
- ④ Close the terminal box cover and turn the fixing bolt completely.

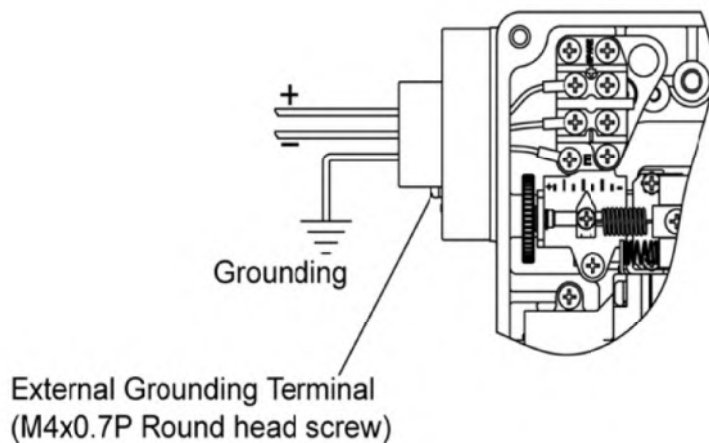

<Intrinsically safe type / Non-Explosion proof type Terminal box>

5.3 With Position transmitter

⚠ CAUTION

- Be sure to connect the feedback circuit to DC voltage 10~30V.
- Be sure to distinguish between the position of the current signal terminal and the position of the feedback signal terminal from the terminal block to connect (+) polarity and (-) polarity precisely.

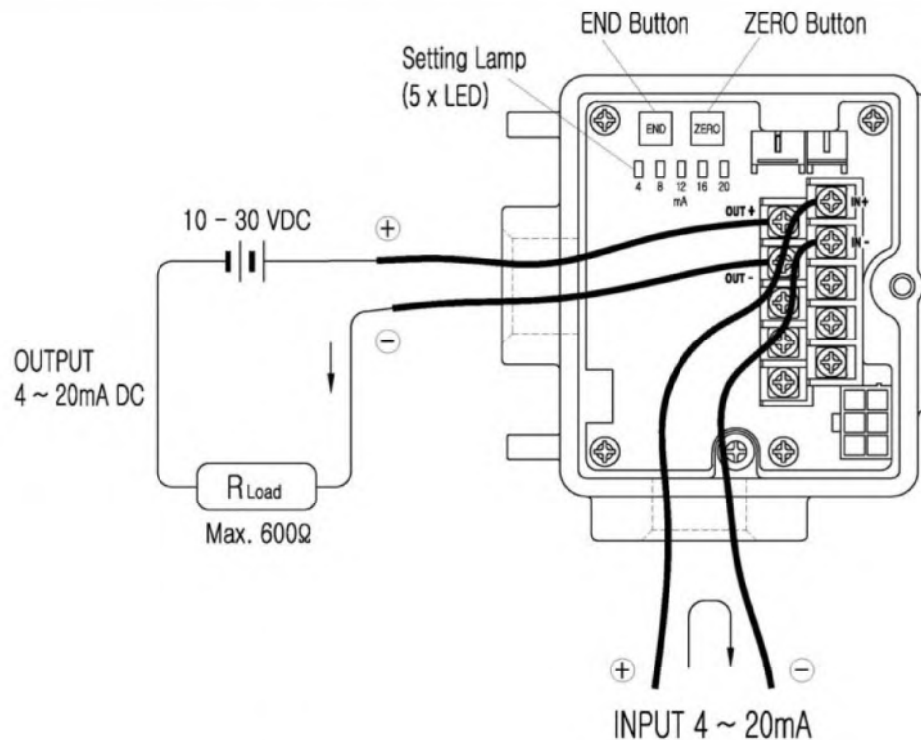

<With Position transmitter type Terminal box>

- ① Unlock the locking bolt of the terminal box and open the cover of the terminal box.
- ② Connect the electric wire (+) of the input signal to IN+ of the terminal block and connect the electric wire (-) to IN- of the terminal block.
- ③ Connect the electric wire (+) of the feedback signal to OUT+ of the terminal block and connect the electric wire (-) to OUT- of the terminal block.
- ④ Connect the ground to the ground terminal that is outside of the product.

5.4 With Limit switch

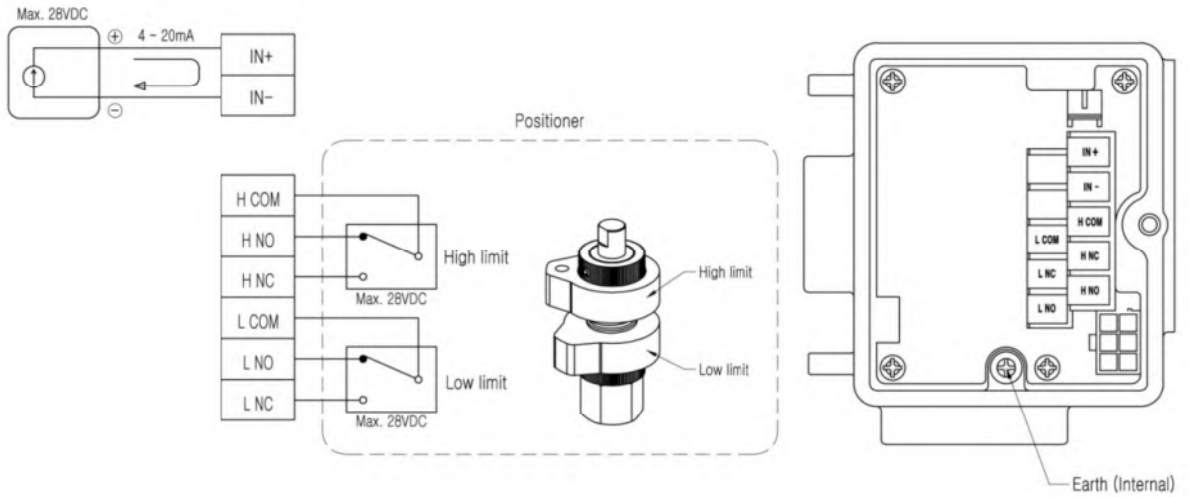

5.5 With Position transmitter and Limit switch

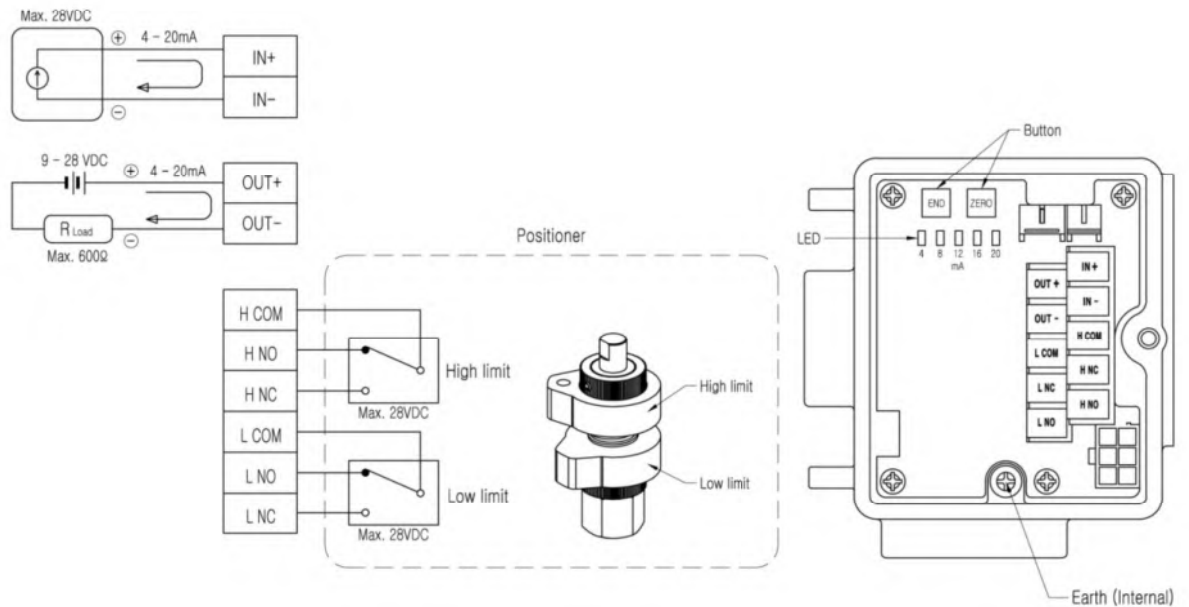

6 Adjustment

⚠ CAUTION

Zero and span must be set correctly so product can be operated normally. If the setting is not correct, impact on performance like linearity. So please the zero and span position must be set correctly.

6.1 Zero and Span Adjustment

- ① Set the input current to 4mA and turn the zero adjusting screw by hand to set it to the actuator starting 0% point.
- ② Then, set the input current to 20mA DC and check the actuator stroke. At this point, depending on whether the span is too large or too small loosen the lock screw and then adjust the span as shown in the illustration above, set it to the actuator 100% end point.
- ③ It shall set the input current to 0% and conduct the zero point adjustment, as done is step1 again, because Span and zero point adjustment interfere in each other.
- ④ Repeat the above operations until the predetermined stroke of the actuator is obtained to the input current.

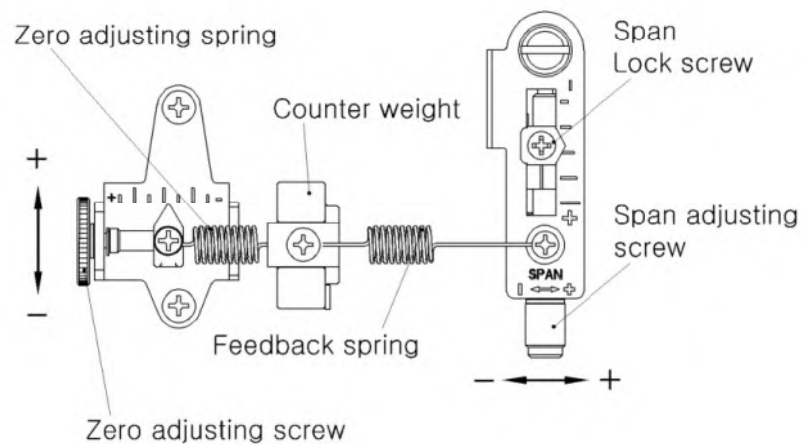

6.2 Position transmitter Setting (Option)

For the general case, set 2 points that belongs to from 0% position to 100% position of the valve. For more precise feedback, set 5 points.

2 points setting

- ① Set Input signal to 4mA to make the valve stroke on 0%, and then press ZERO button for 2 seconds, which setting lamp turns on sequentially.
- ② Set Input signal to 20mA to make the valve stroke on 100%, and then press END button for 2 seconds, which setting lamp turns on sequentially.



5 points setting

- ① Set Input signal to 4mA to make the valve stroke on 0% and then press ZERO and END buttons at the same time for 2 seconds, which can lead the number 4 setting lamp on.
 - ② Press ZERO button just once, and it makes set to output 4mA and then lamp moves to number 8 automatically and blinks.
 - ③ Set input signal to 8mA to make the valve stroke on 25% and then press ZERO button just once, it makes set to output 8mA, and then lamp moves to number 12 automatically and blinks.
 - ④ In the same way, set them in order to output 12mA, 16mA and 20mA according to each position of the valve 50%, 75% and 100%.
 - ⑤ When the valve position 100% setting is completed, all the setting lamps get turned off.
-

How to change DA/RA

This is the direction in which the feedback signal is changed.

When 4mA is inputted, get 20mA feedback. When 20mA is inputted, get 4mA feedback.

- ① Input the current signal 4mA to make the valve stroke on 0% and then press END Button for 2 seconds, which can lead the setting lamp to turn on gradually and rapidly while the location information is saved automatically.
 - ② Input the current signal 20mA to make the valve stroke on 100% and then press ZERO Button for 2 seconds, which can lead the setting lamp to turn on gradually and rapidly while the location information is saved automatically.
-

7 Troubleshooting

7.1 Common problems

Failure	The valve is fully open regardless of the input signal
Causes	The hole of A / M switch of pilot valve is blocked by foreign matter such as dust
Corrective Action	As shown below, loosen the stopper screw and separate A / M switch and clean the bottom of the hole with 0.2mm drill or wire and re-fitted as original.

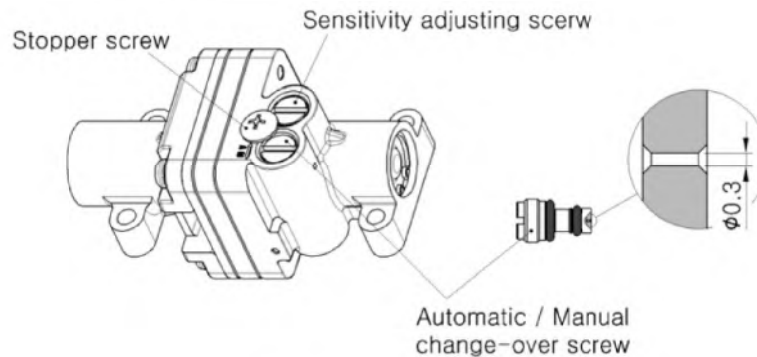

< A/M Switch Structure >

⚠ CAUTION

The sensitivity adjustment screw is set optimally at the factory, do not adjust at random.

7.2 Install Orifice

Failure	When mounted on small size actuator (capacity less than 180cm^3) occurs hunting.
Causes	The pneumatic output of the positioner is too large compared to the actuator chamber size.
Corrective Action	As shown below, remove the O-Ring at OUT1 and OUT2 on the bottom of the pilot valve, please attach the bottom of the orifice included in the package.

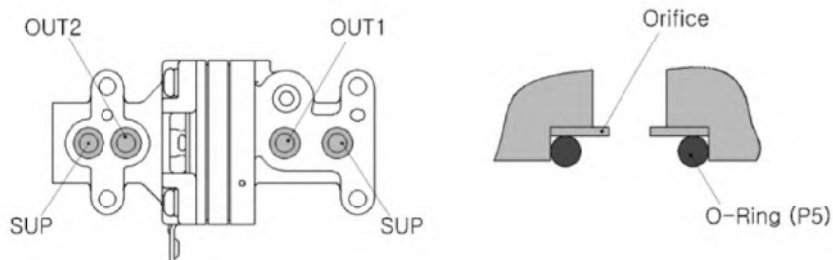

<Example of orifice installation>

7.3 Adjust Potentiometer gear

Phenomenon	Feedback signal dead zone
Cause	Potentiometer gear broke away by a strong shock or vibration.
Explanation	The white colored point of Mainshaft gear and the white colored point of Potentiometer gear should mesh.

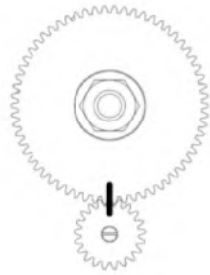

(Picture 1) Normal condition

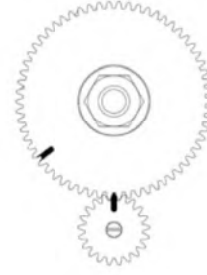

(Picture 2) Gear breaks away

How to adjust when the gear breaks away

- ① Please make the valve stroke on 0% and open the product cover.
- ② Loosen one of M3 fixing screws for Potentiometer. And also loosen the other screw just a little and then pull it down slightly, which can lead Potentiometer gear to separate from Mainshaft gear.
- ③ Adjust Potentiometer gear so that both white colored points should mesh.
- ④ After the adjustment is complete, fix Potentiometer with M3 screws.

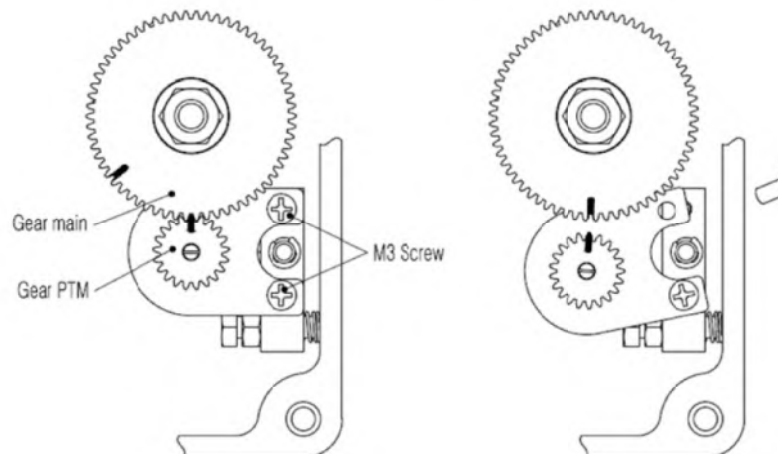

7.4 Other Problems and Resolution

☞ The positioner does not operate

Checklist	Causes	Corrective action	Reference page
If it does not work by moving the nozzle flapper	A/M switch is loose	Check to see if A/M switch is connected	31
	Nozzle clogged	Nozzle needs clean up	31
If it works by moving the nozzle flapper to the left and right	incorrect connections for input current	Check the wire connection	24~28

☞ The actuator works only with ON / OFF control but not intermediate control.

Checklist	Causes	Corrective action	Reference page
Linear type, check span mounting	Span is mounted upside down	Turn the span body	22
Rotary type, check cam mounting	Cam is mounted upside down	Mount the cam correctly	23
Check OUT1, OUT2 pipeline	OUT1 and OUT2 Pipelines are connected in opposite directions	Install pipeline correctly	22~23

☞ Hunting occurs

Checklist	Causes	Corrective action	Reference page
Hunting period is too short and the width is too large (pressure gauge moves at the same time of valve stem)	Actuator volume is too low	Install the orifice on the bottom part of the pilot	31
Hunting period is too long and the width is too small (Gauge markings move and valve stem slowly follow)	High temperature high pressure valve stem has a large frictional force	1 Perform a necessary action to minimize resistance of actuator or valve stem 2 Increase actuator size	N/A

☞ Linearity is too bad

Checklist	Causes	Corrective action	Reference page
Zero and span setting	zero and span setting is incorrect	Resetting zero and span	29
Check Input pressure is constant	Input pressure is not constant	Check the pressure relief valve on supply pressure is normal.	N/A
Verify lever installation	Lever does not provide optimum rotation angle	Adjust bracket and place drawbar on valve opening mark	21

☞ Hysteresis is too bad

Checklist	Causes	Corrective action	Reference page
Check connection of lever spring	Gap between the lever	Tighten the connection to remove the gap	19~21