

INSTALLATION, OPERATION & MAINTENANCE MANUAL

HIGH PERFORMANCE BUTTERFLY VALVES 800 SERIES REV A

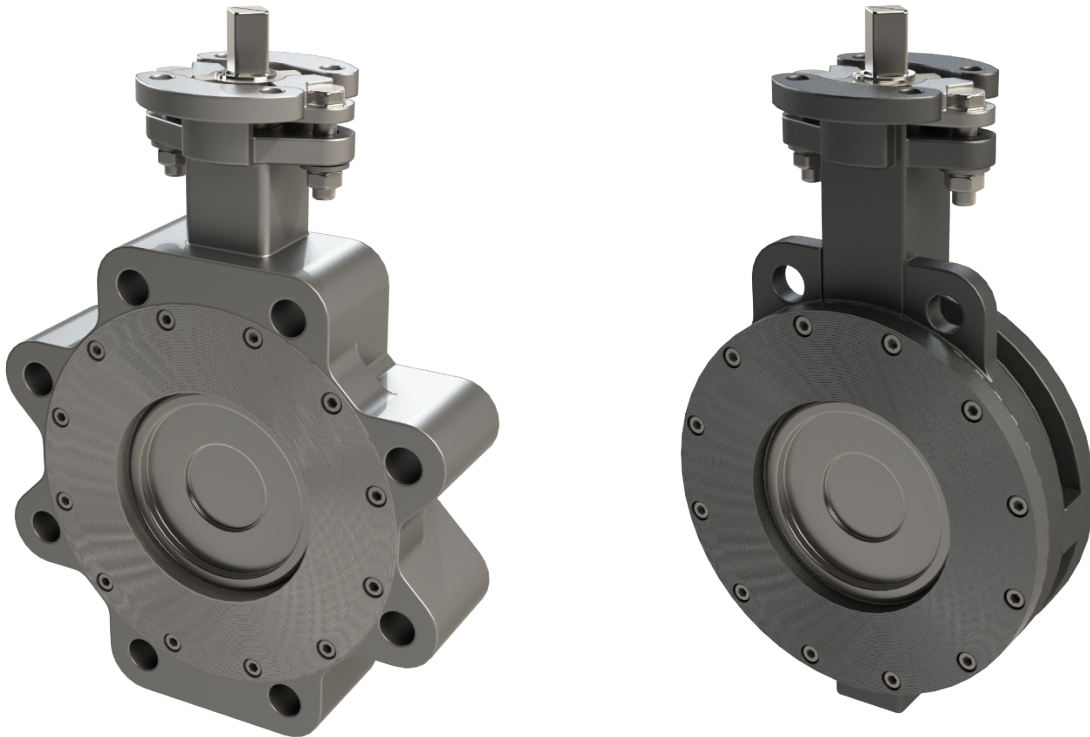

I. General

a. Product Description

Delta T 800 Series Rev A are double offset (double eccentric) type high performance butterfly valves equipped with Delta T SAS Technology™ one-piece, self-energizing seat to simplify maintenance and extend life. The double offset refers to the geometry and motion of the seat/disc interface, where the disc axis is offset from the centerline in two directions. The eccentric seating motion limits sliding contact between disc and seat, reducing wear and torque requirements while maintaining bubble tight shutoff.

b. Markings & Identification

Body markings on the neck – opposite side to the Delta T logo - identify Size, Pressure Class Rating, and Body Material.

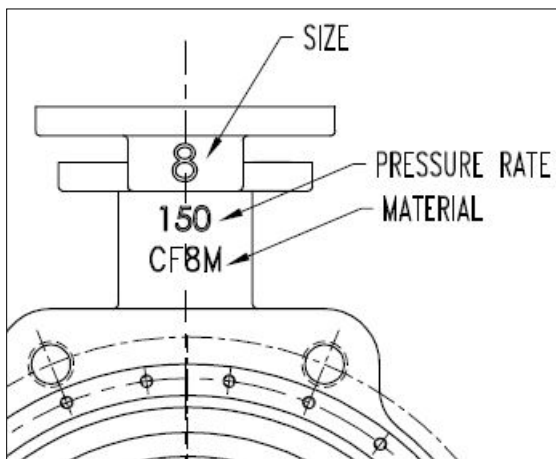

Nameplate tag on the side of the valve neck identifies additional information such as Model No., Trim details, and pressure/temperature ratings.

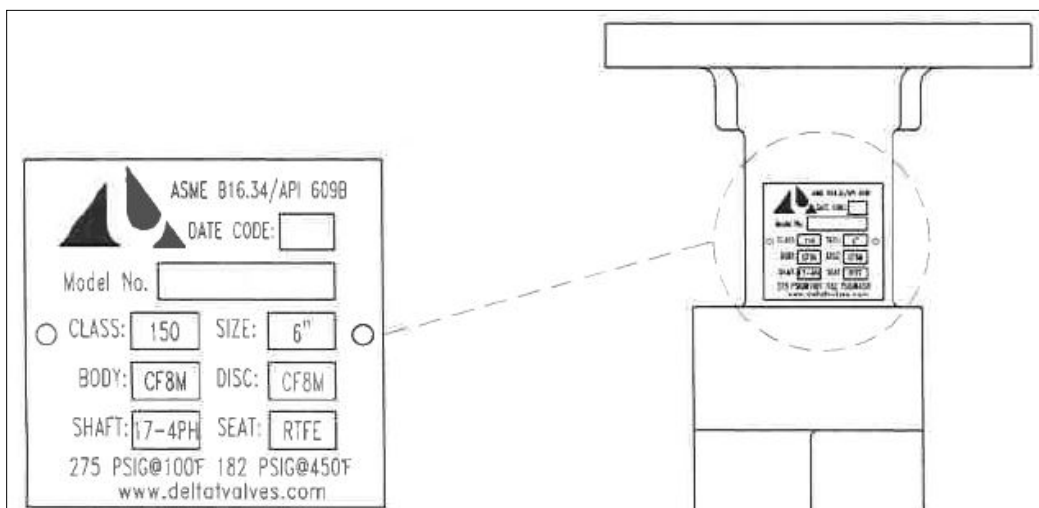

c. Handling & Storage

Valves must be transported and stored in a clean and dry condition. Avoid condensation from collecting on valve surfaces by using moisture barriers and desiccants during shipping and maintaining low humidity in storage locations. Do not shrink wrap valves as this could result in moisture buildup and corrosion.

d. Specifications & Ratings

i. Standard & Compliance

ISO5211 Industrial Valves Part-Turn Actuator Attachments

ASME B16.5 Steel Pipe Flanges and Flange Fittings

ASME B16.34 Steel Valves

MSS-SP-6 Finishes for Pipe Flanges

MSS-SP-25 Standard Markings for Valves

MSS-SP-68 High Pressure Butterfly Valves with Offset Design

ii. Weights

Size		750 WCB Wafer		751 WCB Lug		850 CF8M Wafer		851 CF8M Lug		Individual Handle		Individual Gear Operator	
ANSI	DN	lbs	kg	lbs	kg	lbs	kg	lbs	kg	lbs	kg	lbs	kg
2"	50	6.83	3.10	8.88	4.03	6.83	3.10	8.88	4.03	1.35	0.613	2.8	1.3
2.5"	65	9.46	4.29	11.64	5.28	9.46	4.29	11.64	5.28	1.35	0.613	2.8	1.3
3"	80	11.79	5.35	13.76	6.24	11.79	5.35	13.76	6.24	1.31	0.595	2.8	1.3
4"	100	19.51	8.85	26.39	11.97	19.51	8.85	26.39	11.97	1.31	0.595	2.8	1.3
5"	125	27.76	12.59	36.57	16.59	27.76	12.59	36.57	16.59	3.70	1.678	5.6	2.5
6"	150	32.17	14.59	42.61	19.33	32.17	14.59	42.61	19.33	3.70	1.678	5.6	2.5
8"	200	50.07	22.71	65.61	29.76	50.07	22.71	65.61	29.76	3.25	1.476	11.5	5.2
10"	250	80.00	36.29	102.21	46.36	80.00	36.29	102.21	46.36	7.57	3.432	11.5	5.2
12"	300	129.21	58.61	162.92	73.90	129.21	58.61	162.92	73.90	7.53	3.414	22.2	10.1

iii. Seating Torques

Size (in)	SHAFT DOWNSTREAM				SHAFT UPSTREAM			
	Pressure Differential (ΔP in PSI)				Pressure Differential (ΔP in PSI)			
	75 ΔP	150 ΔP	225 ΔP	285 ΔP	75 ΔP	150 ΔP	225 ΔP	285 ΔP
2	286	295	304	311	290	302	315	325
2-1/2	329	342	355	365	332	347	363	375
3	397	416	435	450	397	416	435	450
4	559	600	642	675	559	600	642	675
5	589	662	735	793	610	705	799	875
6	1021	1125	1230	1313	1057	1197	1338	1450
8	1360	1550	1740	1892	1441	1712	1983	2200
10	3598	3944	4290	4566	3778	4304	4830	5250
12	3767	4430	5093	5624	3866	4628	5390	6000

iv. Service Factor Ratings

Service Condition	Service Type	Media Type	Safety Factor	Multiplier
1	Ideal	Lubricating Oil	20%	1.20
2	Normal	Water	30%	1.30
3	Severe	Dry Air, Solvents	50%	1.50
4	Extreme	Abrasives	100%	2.00

v. Cv Values

Size (in)		Disc Position							
ANSI	DN	20°	30°	40°	50°	60°	70°	80°	90°
2"	50	5	8	12	18	29	43	60	62
2.5"	65	7	12	18	28	44	67	92	96
3"	80	12	21	31	48	75	113	157	163
4"	100	29	50	74	115	180	270	374	388
5"	125	49	84	124	192	300	450	623	647
6"	150	81	141	207	321	502	755	1045	1085
8"	200	164	283	416	645	1009	1517	2099	2180
10"	250	235	407	598	926	1449	2178	3014	3130
12"	300	370	641	942	1459	2283	3431	4748	4930

vi. Pressure Rating

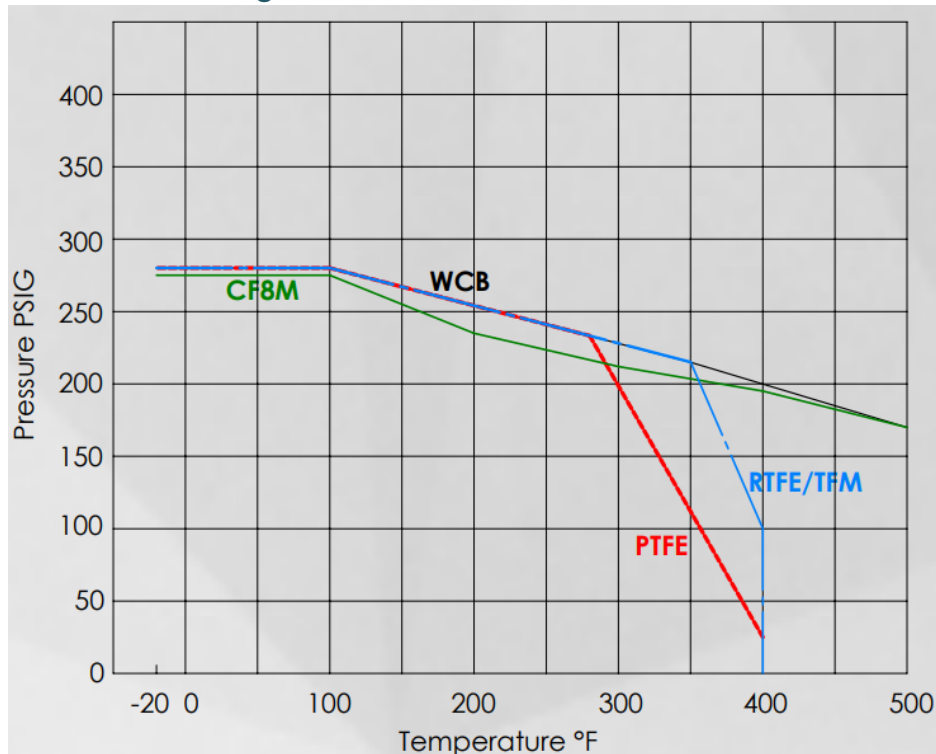

e. Safety

i. Personnel Qualifications

Persons assigned to installation, assembly, operation or maintenance tasks must be properly trained and qualified to perform such tasks. Proper safety measures should be taken and protective equipment and/or clothing used when necessary.

ii. Manufacturer's Recommendations

Always follow manufacturer's recommendations and do not operate valve outside of specified ratings or operating parameters. Please contact Delta T Products and consult with a qualified engineer to ensure the valve is suitable for the intended service conditions.

II. Installation

a. Preparation

i. Protective Clothing

Hard hat, safety glasses, steel toed boots, hearing protection, etc. as needed

ii. Proper Equipment

Appropriate lifting equipment, torque wrenches, etc. as needed

Gaskets for pipeline installation (see section II.b.iv Gaskets)

Bolts/studs & nuts for pipeline installation (see section II.b.v Bolting Requirements)

iii. Check Pipeline

Confirm what kind of media (if any) is in the pipeline, and make sure the system is depressurized. Isolate the work area (via isolation valves) from the surrounding pipeline if possible and ensure that no hazardous material is present.

Flange class must match valve class (i.e. Class 150 high performance butterfly valves must be installed between Class 150 flanges).

b. Assembly

i. Flow Direction

Delta T high performance BFV's will seal in either direction (bi-directional), but the preferred flow direction is disc facing upstream, shaft downstream. Installing in the preferred flow direction will extend the life of the valve and lower torque requirements.

Preferred flow direction is marked by an arrow on the side the valve body, with arrow pointing in direction of flow.

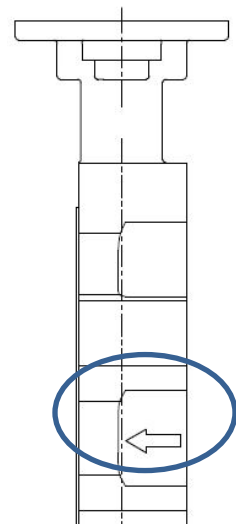

of

ii. Valve Orientation

Preferred installation orientation is with stem horizontal, to reduce sediment build-up around stem bearings and extend valve life.

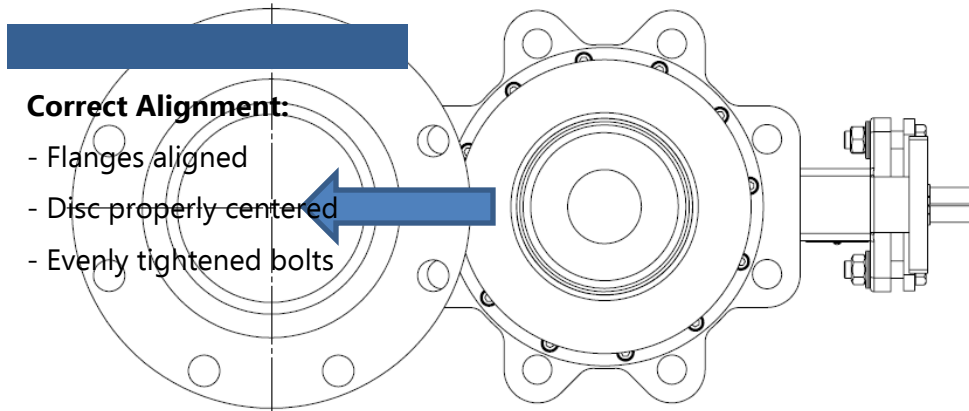

iii. Lifting & Positioning

Recommended practice is to install valves at least 5 X pipe diameter from the nearest pipe element (e.g. another valve, elbow, tee, etc.). **Valve should be fully closed.**

DO NOT install two valves directly together – a pipe spool spacer is required for disc clearance. Also consider clearance for handles or other operators.

Lift using lug/wafer holes and/or strap around neck of valve to position in place, then loosely place at least two bolts through flange holes to hold valve in place for bolting.

iv. Gaskets & Alignment

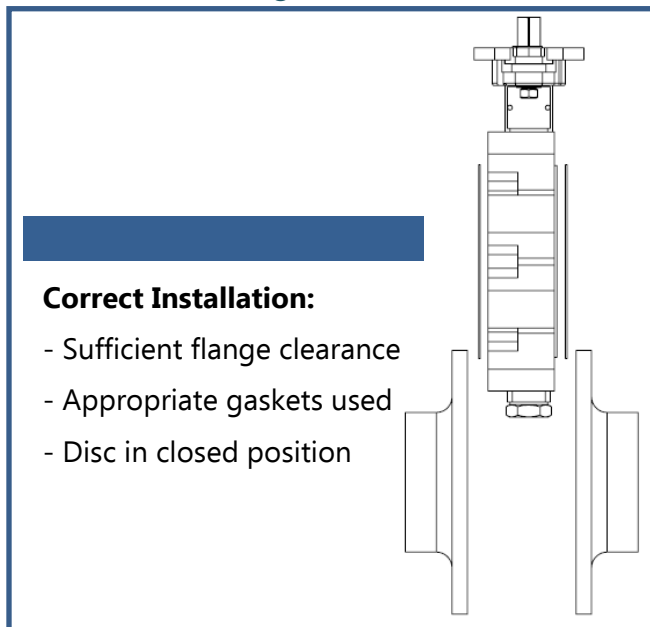

Incorrect:

- Not enough flange clearance
- No gaskets

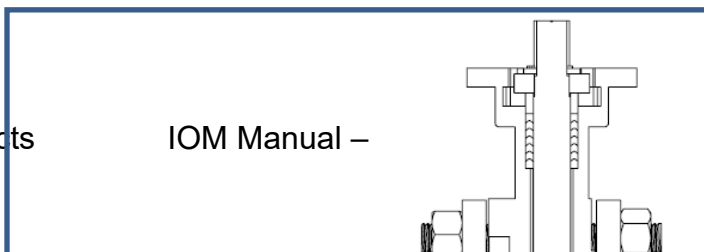
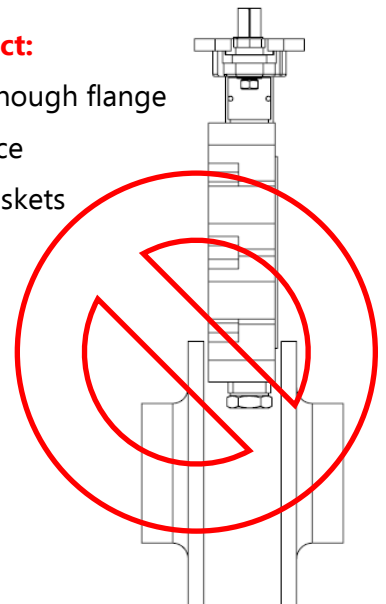

Incorrect:

- Flanges misaligned
- Uneven bolt

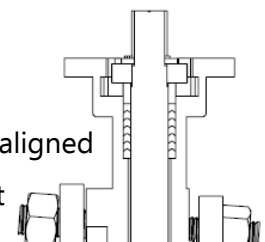



v. Bolting Requirements

Wafer Style "A"

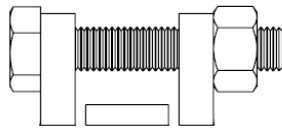

Lug Style "C"

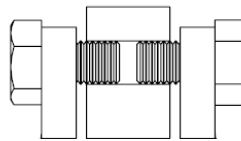

Size	Bolt/Stud Thread	Wafer Style A			Lug Style C	
		# Bolts	Bolt Length	# Nuts	# Bolts	Bolt Length
2"	5/8"-11 UNC	4	4.00"	4	8	1.25"
2-1/2"	5/8"-11 UNC	4	4.25"	4	8	1.50"
3"	5/8"-11 UNC	4	4.50"	4	8	1.50"
4"	5/8"-11 UNC	8	5.00"	8	16	1.75"
5"	3/4"-10 UNC	8	5.50"	8	16	1.75"
6"	3/4"-10 UNC	8	5.50"	8	16	2.00"
8"	3/4"-10 UNC	8	6.00"	8	16	2.25"
10"	7/8"-9 UNC	12	6.75"	12	24	2.25"
12"	7/8"-9 UNC	12	7.00"	12	24	2.50"

***Note: Flange bolt torque requirements depend on type of gasket used. Please consult gasket specifications for actual torque requirements, selecting appropriate bolt material with adequate strength for the required gasket preload torque.**

For wafer style valves, loosely install the lower half of available flange bolts to form a "cradle" to hold the valve in place, then loosely install bolts through the upper and lower body alignment holes (Reference ***Wafer Style "A"***). Next insert the remaining flange bolts and then hand-tighten.

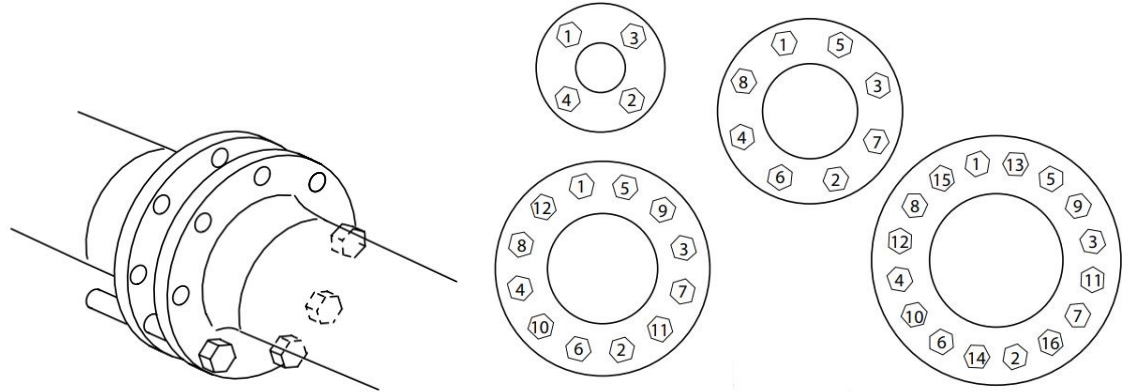

For lug style valves, loosely install the lower half of available bolts between flanges and the lugs and hand tighten if using **Lug Style "C"**. Install gaskets before inserting the remaining bolts or studs and hand-tightening.

Once all nuts/bolts are installed and hand-tightened, torque the bolts evenly for uniform gasket compression per the numbered sequence "star" patterns above. Exact bolt torques will depend on gasket type.

c. Commissioning

Manually operate the valve to ensure full open and full close positions without any disc to pipe interferences. If any actuation (electrical, pneumatic, etc.) is installed on the valve, test stroke with the actuator/operator if possible to ensure proper operation.

III. Operation

a. Method of Operation

Delta T high performance butterfly valves operate within a 90° stroke (quarter-turn), and are operated by manual lever or an actuator via an ISO standard square stem. Hard stops are incorporated into a stem "Stopper Plate" which prevents the valve from over-stroking past the full closed position. Stem is always turned Clockwise (CW) to close and Counter-clockwise (CCW) to open. **Stem slot shows disc position.**

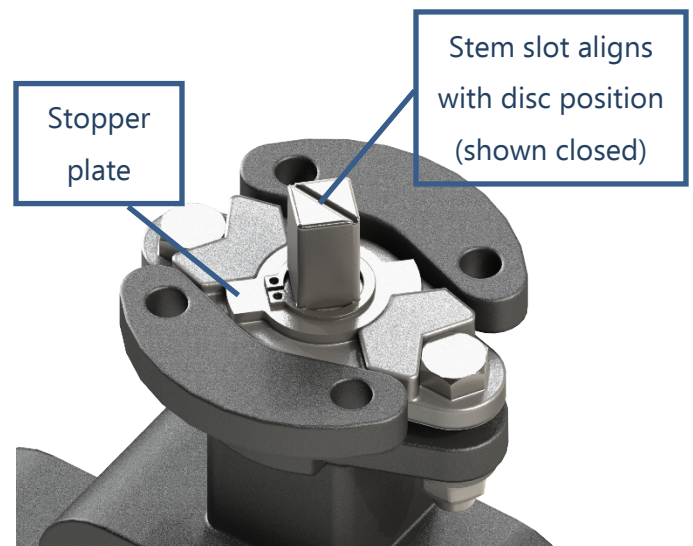

b. Operating Parameters

Do not operate valve beyond maximum parameters as shown on the valve identification tag, or as shown on the Pressure/Temperature graph in section ***I.d.vi Pressure Rating.***

Do not exceed the following Maximum Allowable Stem Torque (MAST) values:

Size	MAST (in-lbs)
2"	777
2-1/2"	777
3"	1602
4"	1602
5"	1602
6"	1602
8"	4004
10"	6216
12"	6216

c. Manual

Valve can be operated with manual lever handle, or with manual gear operator.

In case of manual gear operator, first back off both travel stops all the way. To set gear operator stops, stroke valve to full open position and then set full open stop, and stroke valve to full close position and then set the full closed stop. This ensures that the valve reaches full open and full closed positions without being prematurely stopped by the gear operators hard stops.

d. Automated

Valve can also be operated by a powered actuator (e.g. pneumatic or electric, etc.) Take precautions to set hard stops on actuator to match the full open and full closed valve positions to ensure full valve stroke and prevent valve/actuator damage.

***Warning: Incorrectly set travel stops may result in actuator and/or valve damage.**

IV. Maintenance

a. Recommended

Interval Type	Recommended Action(s)	Recommended Minimum Interval
Inspection	1. Test stroke open/closed, ensure full stroke and no excessive binding or obstruction. 2. Visual inspection for basic condition 3. Tighten packing if needed	3-6 months / or every 1,000 cycles
Maintenance	1. Repair kit (packing & seat)	12-24 months / or every 10,000 cycles

b. Removal

Ensure that proper protective clothing and proper equipment are used to remove valve from service. Confirm what kind of media (if any) is in the pipeline, and make sure the system is depressurized. Isolate the work area (via isolation valves) from the surrounding pipeline if possible and ensure that no hazardous material is present.

c. Repair

i. Packing Adjustment

Packing naturally wears out and compresses over time, especially in high cycling applications. To maintain upper stem sealing, it may be necessary to tighten packing after a period of time. Packing can be adjusted easily without removing any operators:

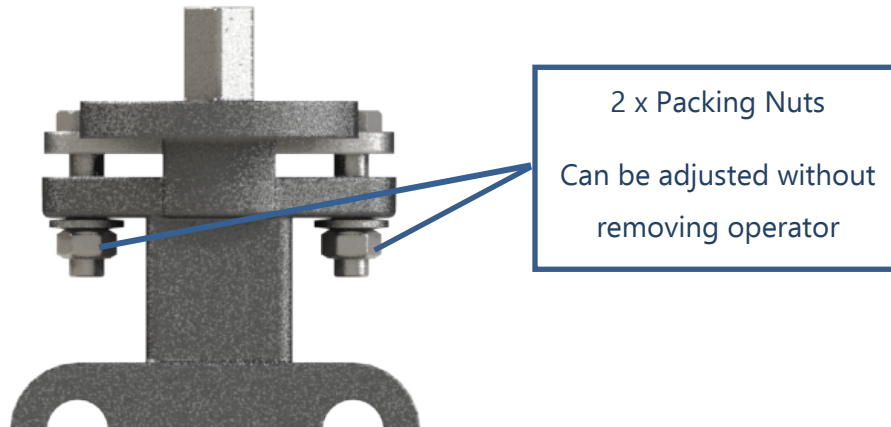

ii. Packing Replacement

The packing can be replaced by removing the stopper plate, packing gland and upper retaining ring (see Exploded Parts View). Spare packing is included in factory repair kits.

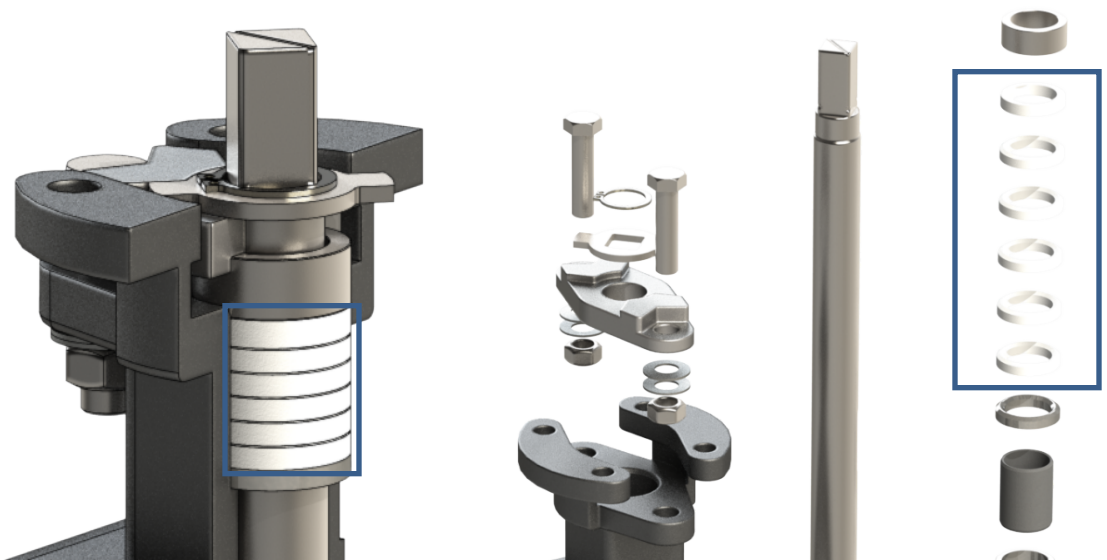

iii. Seat Change Out

The Seat can be changed out without removing the stem or disc. A spare Seat and Insert Ring are included in factory repair kits.

First, uninstall the Seat Insert (which holds the Seat in place) by removing the Insert Bolts. Then, remove the old Seat and old Insert Ring and replace both with the new spares.

****Note* The insert ring must always be replaced when replacing the seat.***

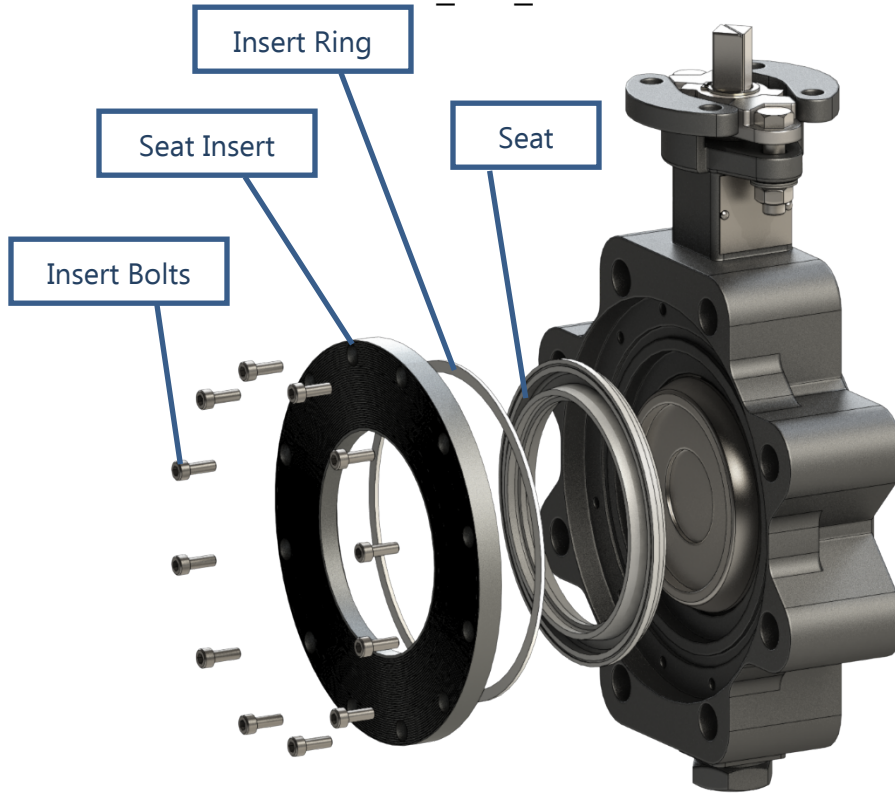

To reinstall the Seat Insert, gently tighten all Insert Bolts until snug, then torque evenly in a star pattern according to the following torque table:

Size	Socket Cap Bolt	Torque (+/- 10%) in-lbs
2"	M4	34.7
2-1/2"		
3"		
4"	M5	69.4
5"		
6"		
8"		
10"	M6	117.2
12"	M8	286.4

V. Exploded Parts List & Repair Kits

High Performance Butterfly Valve

Exploded View & Bill of Materials

Repair Kits Parts

Includes Insert Ring, Seat and Packing.

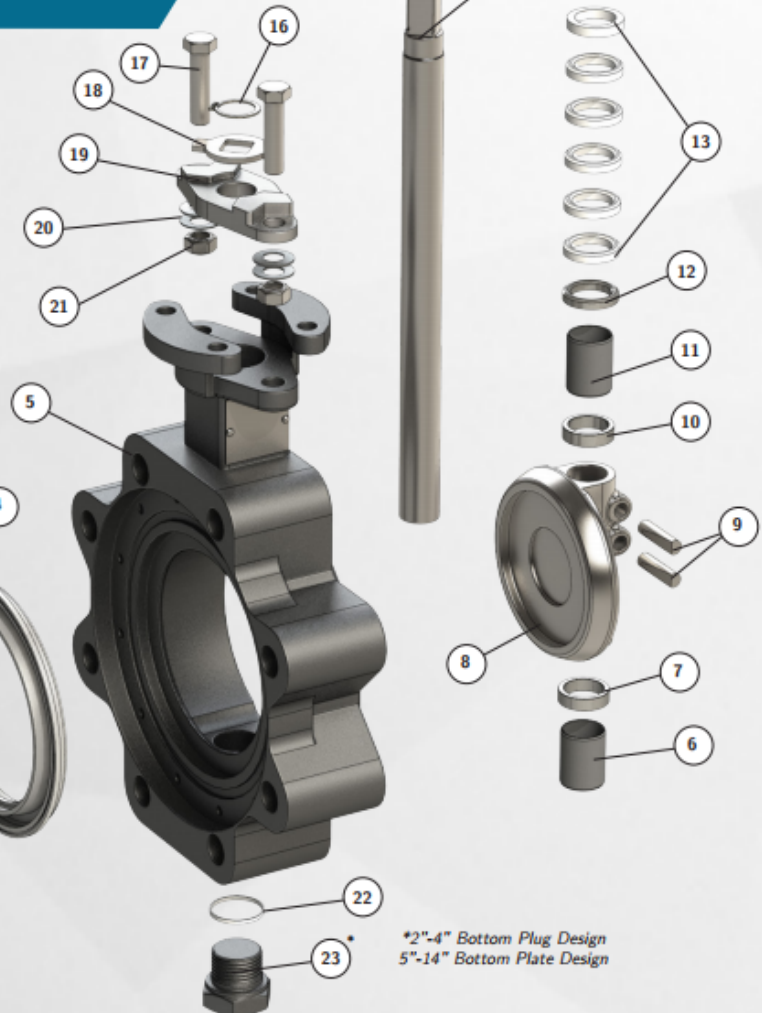
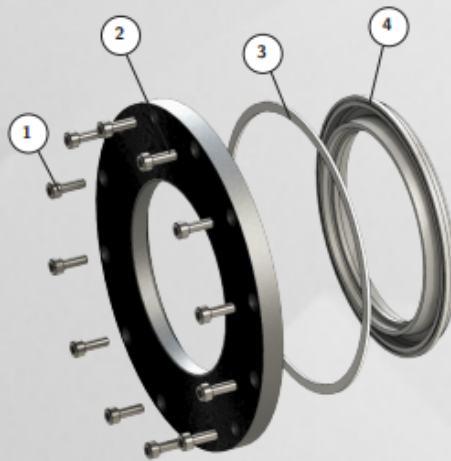
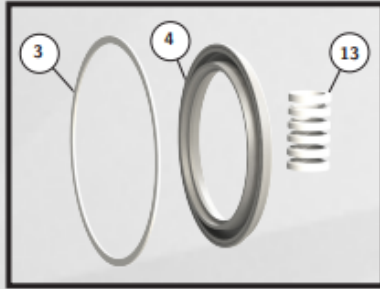

*2"-4" Bottom Plug Design
5"-14" Bottom Plate Design

Bill of Materials

Item	Description	Materials
1	Insert Bolts	A193 GR.8
2	Seat Insert	ASTM A29 GR1045 (WCB) ASTM A240 GR316 (CF8M)
3	Insert Ring	PTFE
4	Seat	TFM/RTFE/PTFE
5	Body	A216 WCB or A351 CF8M
6	Lower Stem Bearing	SS/PTFE Lined
7	Lower Retaining Ring	304 SS
8	Disc	A351 CF8M
9	Disc Taper Pins	17-4 PH
10	Lower Retaining Ring	304SS

Item	Description	Materials
11	Upper Stem Bearing	SS/PTFE Lined
12	Packing Ring	304 SS
13	Packing	PTFE
14	Upper Retaining Ring	304 SS
15	Stem	17-4 PH
16	Snap Ring	W1-8
17	Gland Bolts	A193 GR.8
18	Stopper Plate	304 SS
19	Packing Gland	A351 CF8M
20	Spring Washers	301 SS
21	Gland Nuts	A194 GR.8
22	Plug Seal	PTFE
23	Body Plug	A216 WCB or A351 CF8M

